

# PW-500 TYC

Commercial and Industrial  
Atmospheric Water Generators

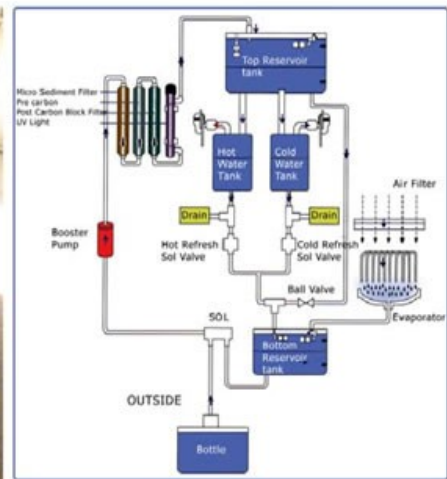

## **Introduction**

Thank you for purchasing our Industrial and Commercial atmospheric pure water generator. Our water generators use the most advanced technology in both water generation and filtration systems to deliver high volumes of clean water by just using the air we breathe. This way you are helping to save the environment as well as meeting the need for clean water.

## **Working Principle**

The AWG depends upon the humidity and vapour in the air to generate water, the ideal humidity that can achieve the highest water generation must be in the range of 70%--80%. In low humidity situations, it can also generate water however the out-put will be less and slow. Also the ideal operating temperature between 24C—29C is an important factor in water generation. This doesn't mean the machine will not function; it will only generate less water and might use more energy to generate water.

The main working principle of the AWG can be likened to a dehumidifier unit. The compressor processes the air around the machine and takes off the humidity and vapour off the air to generate water. Because of this reason the air flow to the area where the machine is located should have constant fresh air flow to minimize health risks and generate required amount of water.

## **Standard Maintenance Procedure**

All the procedures below should be done while the machine is switched off.

### **1. Cleaning the air filter:**

The air-filter has a big importance on the water generation process and can have a major impact on the out-put. Especially in polluted areas the air-filter has to be cleaned more often than the usual 2 weeks periodic cleaning schedule. How to clean air-filter: Take the front panel out and you will see the air filter unit. Remove the frame and the air filter. Using an air blower or air gun clean all the dust inside filter mesh. After it's all cleaned, you can put it back at the right position – exactly in front of the suction grid. Make sure the suction grid is covered completely to stop dust entering in to the system.

### **2. Cleaning the water tank:**

Take the front panel and air filter out. Using a clean towel, wipe the sides of the water tank interior. Please empty the water tank after all the interior is clean. Using clean water flush the empty tank one more time. Suggested cleaning cycle is once a month.

### **3. Replacing PPF and Activated Charcoal Filter units:**

Remove the bottom cover to reach the PPF and ACF units. Take each unit from the support element and carefully remove the water pipes and replace them with a new unit. Make sure all the seals, covers and pipe connections are tightly closed. Suggested replacement cycle: The PPF filter unit up to 6-8 months, The ACF unit up to 12-15 months.

### **4. Replacing the Reverse Osmosis unit and UVF unit:**

Take out the RO membrane from the support unit. You will only need to take out the membrane shell's top cover's water pipe connection. To open the membrane shell's top cover, unscrew it anti-clockwise. Pull out the membrane core, and replace it with the new filter unit, then screw the top membrane cover clockwise to close. Make sure all the seals, covers and pipe connections are tightly closed. Suggested replacement cycle: Up to 24-26 months.

### **Important notes:**

1. The new machines are shipped without RO unit being installed.
2. You must install the RO unit as explained above.

### **Installation and Handling**

Before installing your new AWG machine, please ensure there is enough air-ventilation and working space around the machine as well as the air humidity levels and temperature is as close as to the ideal level as shown in the Technical Data table below.

**Note:** The AWG PW-500 TYC models require an operational space 650-750 square meters. Minimum ceiling height should be 260 centimetres. If you will be using the machine in an outside environment, you need have a roof, not less than 260 centimetres and make sure the machine is prevented from extreme weather conditions like, dust air pollution and rain.

The 500L above water tank (e.g. chart) has a water level floating switch which functions as a distribution point between the floating tank and the direct water outlet point to meet your usage need and acts like a special purpose distribution box.

**Note:** Both models use three-phase electric with ground cable. The machine's internal circuit board has an automatic protection system installed. Therefore, if the voltage is low or the ground cable connection is not sufficient enough, the start button will not function and the Control/Display Panel will display "E3" error code. Please check the power source and all the cable connections.

### Operation Check List

1. The AWG must be connected to three-phase electric circuit with good ground (earth) cable with a high quality circuit protection breaker.
2. The air intake grids must have good cross-air-flow, far from combustible materials and kept clean in all times.
3. If you will not use the AGW for a long time, make sure to empty the water tanks.
4. Before service/maintenance, must cut off the main electricity.
5. If any of the electric cables are damaged, have a qualified electrician to replace it immediately.
6. AWG unit can not be used as a direct water filtration system.

### AWG Operation Parts Description

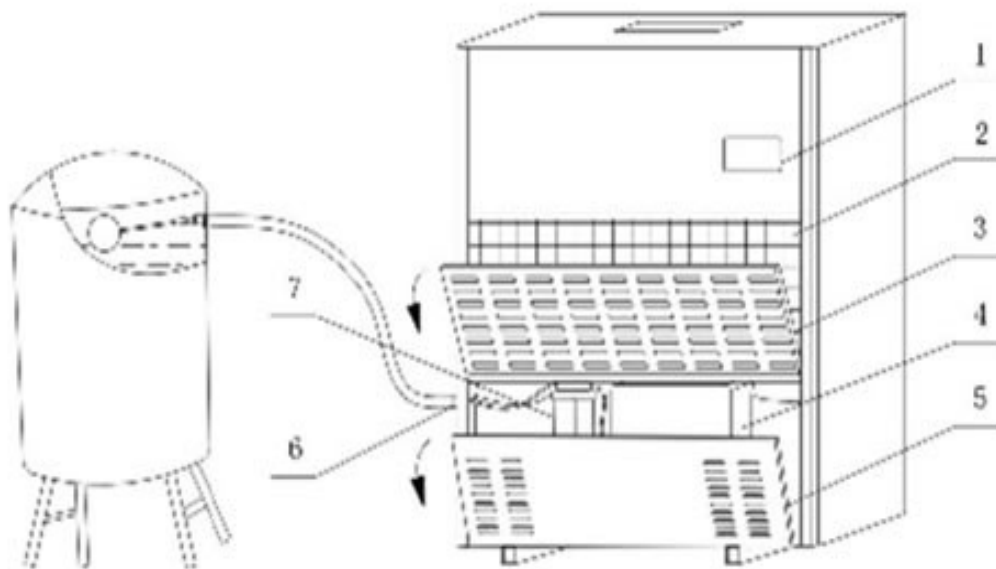

1. Control/Display window and power supply switch
2. Air filter unit
3. Air intake grids
4. Internal water tank

5. Bottom cover panel
6. Water outlet tap
7. Water filtration units
8. External water tank (optional)

### Trouble Shooting

1 - Water generation speed is excessively slow: Please check the Display monitor and ensure the humidity and temperature levels are in the ideal ranges. Inspect the intake grids and air-filter and make sure they are both clean. If not, please clean them. Make sure there is enough cross-air ventilation and ample free space around the machine or the electricity voltage is in the normal scope.

2 - After power source connection, the machine does not work: Inspect the power source and cables whether they are connected in the right order or intact.

### Failure Codes

Failure Code	Failure Reasons	Failure Code	Failure Reasons
E1	Humidity sensor failure	E5	The grounding or voltage protection error
E2	A - Evaporator sensor failure	E6	B - Evaporator low pressure protection
E3	A - Evaporator low pressure protection	E7	B - Evaporator high pressure protection
E4	A - Evaporator high pressure protection	E8	B - Evaporator sensor failure

### TECHNICAL DATA

TECHNICAL DATA		
Model	PW-500 TYC	PW-500 TYC
Power supply	380V/50HZ	380V/50HZ
Rated input	10KW	22KW
Maximum current	25A	50A
Production capacity	500L/D	1000L/D
Ideal condition	RH: 75% / Temp: 27°C	
Operational condition	RH: 40%-90% / Temp: 15°C-35°C	